

# AN INTRODUCTION TO WATER-POWERED DOWN-THE-HOLE DRILLING IN SPECIALTY GEOTECHNICAL CONSTRUCTION

Dr. Donald A. Bruce, Geosystems, L.P., Venetia, PA, dabruce@geosystemsbruce.com  
Rudy Lyon, Center Rock Inc., Salem, VA  
Stefan Swartling, LKAB Wassara AB, Stockholm, Sweden

---

## ABSTRACT

Since their first production application in Sweden in 1995, water-powered, down-the-hole hammers (WDTH) have been used throughout the world in many different drilling applications, total lines, over 25 million lineal meters of drill hole. This paper reviews the history and principles of down-the-hole drilling (DTH) in general with both air and water, before focusing on the details of WDTH hammers. A summary of the numerous and considerable advantages of WDTH drilling is provided, with particular emphasis on their superior productivity, smaller deviation, applicability in sensitive/urban conditions, environmental protection and much reduced energy requirements.

## HISTORICAL PERSPECTIVE ON PRODUCTION DRILLING METHODS

Air-flushed drilling with top hammers began in the mining industry in Sweden in 1873, while down-the-hole (DTH) drills, again with air flush (and activation) became operational in 1950. During that same time interval, Simon Ingersoll had patented the first steam-powered, top hammer rock drill to provide higher productivity in blast hole drilling. It is well known that water, as an activating, flushing and cooling medium, has many significant advantages over the use of air. However, it was not until 1973 that top hammer systems (either air or hydraulically activated) for larger rigs were adapted to the use of water flush, typically via "under the head" swivels.

The concept of a water-powered, down-the-hammer (WDTH) had been explored prior to G. Drill acquiring the original patent from Atlas Copco in 1988. LKAB, a huge underground mining company owned by the Swedish Government and providing about 90% of the European Union's iron ore, purchased G. Drill in 1991 and encouraged the commercial development of the WDTH. The first full-scale WDTH production works were carried out for LKAB in 1995, since when over 25 million lineal meters of drilling have been recorded in both underground and surface applications.

In 2001, G-Drill was renamed Wassara, which today still holds the worldwide patents for WDTH technology. Regarding North American usage, the first significant application was by Advanced Construction

Techniques (ACT) Ltd. during the test grouting program conducted for the U.S. Army Corps of Engineers at McCook Reservoir, Chicago, in 2002. Since then, WDTH has become the tool of choice for specialty drilling and grouting contractors on dams and other major structures throughout the U.S.

Other DTH variants have been developed over the last 15 years or so, and are based on air activation and flush. These are described in Weaver and Bruce (2007) and include:

- Reverse circulation (air)
- Dual-fluid system (using air as the activator but permitting water flush also)

However, the purpose of this paper is to focus on WDTH technology, and to compare it, wherever appropriate, with corresponding direct air flush, conventional DTH systems.

## GENERAL BACKGROUND TO AIR-POWERED, DOWN-THE-HOLE HAMMER DRILLING (DTH)

For production hole drilling, there are fundamentally three basic methods, as illustrated in [Figure 1](#): rotary, rotary percussive top drive (top hammer), and rotary percussive down-the-hole hammering (DTH). An elderly but still useful application chart was produced by McGregor (1967) and is reproduced in [Figure 2](#).

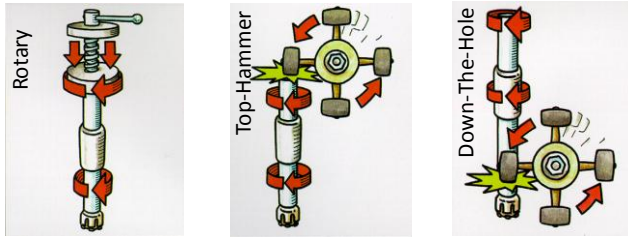

Figure 1. Schematic showing basic rock drilling principles.

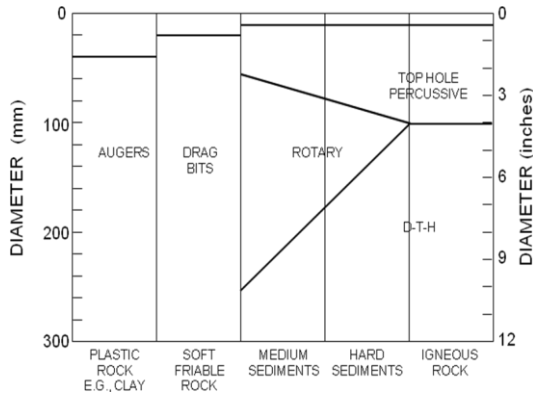

Figure 2. Basic drilling method selection guide for rock using noncoring methods (Littlejohn and Bruce, 1977. Adapted from McGregor, 1967).

Of course there have been many significant developments and modifications in the intervening period, but the principles remain the same:

- Rotary drilling is economic in all hole sizes in soft-medium rocks. This method requires high bit load and high rotary torque.
- Rotary percussive (top drive) is economic in materials of all types, up to about 5-inch (127 mm) diameter. It has low feed and torque requirements and typically modest flush pressure and flow demands.
- Rotary percussive (down-the-hole hammer) drilling is typically preferred in medium-hard materials for holes over 4-inch (101 mm) diameter and over 40 feet (12 m) deep. High pressure, high volume flushing media are required, whereas feed and torque requirements are low.

DTH drilling has many advantages over top hammer drilling for larger, deeper holes in medium-hard rocks:

- There is minimal power loss as the hole is deepened and so penetration rates do not markedly decline with depth, provided that

back pressure does not rise significantly in the borehole.

- The low Weight on Bit (WOB), coupled with the relatively large diameter rods which are used, combine to promote much straighter holes.
- The lower rotational speed reduces vibrations to the drill head and rig.

In relation to pure rotary drilling, DTH drilling is faster, due to the more focused and intensified stresses imposed on the rock, and does not require sophisticated drilling mud preparation, handling and cleaning systems. Air-powered equipment has the obvious yet distinct advantage of exhausting energy-depleted air directly into the atmosphere, where the difference between rock and air density makes separation direct and simple.

For the conventional, air-powered DTH (as shown in Figure 3), there are three basic considerations:

- Compression of the air to operate the DTH by generating impact energy.
- Energy transmissions from the piston to the rock.
- Removal of cuttings from the hole by the exhausted air.

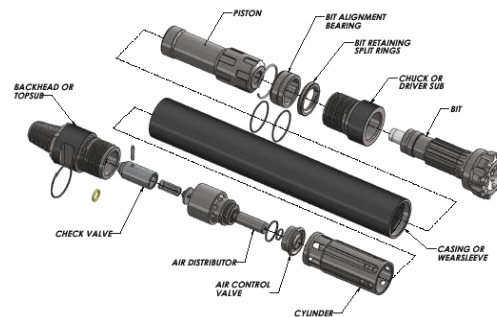

Figure 3. Components of a typical air-powered Down-the-Hole Hammer (courtesy of Center Rock, Inc.).

Each of these considerations has, in turn, many controlling factors and nuances: suffice it to say that contemporary hammers continue to undergo progressive development as consequences of close field monitoring and highly sophisticated computer modelling at the design stage. A critical factor — for all types of DTH's — relates to the cycling of the piston. The objective is to consume the activating medium with the highest level of efficiency. Bearing in mind that the drill penetration rate is proportional to power, this will therefore be dictated by the energy applied to the piston

times the frequency of the blows. Hence, it follows that a prime goal is to maximize the area of the piston and the effective pressure, and to minimize leakage or bypass. The interested reader is referred to Lyon and Soppe (2012) for detailed consideration.

### GENERAL BACKGROUND TO WATER-POWERED, DOWN-THE-HOLE HAMMER DRILLING (WDTH)

WDTH's are used in hard, stable rock drilling, and with casing systems for overburden drilling. Compared to conventional air driven down-the-hole hammers or top hammers, these WDTH's provide many advantages, including low energy consumption, reduced environmental impact, minimal hole deviation, deeper drilling, high output power and minimal impact on the surrounding ground.

A WDTH has only two moving parts, the piston and the valve. This simplicity contributes to its high degrees of reliability and performance, especially noteworthy in more difficult drilling conditions. Water at up to 180 bar (about 2,600 psi) delivery pressure is used to activate the impact mechanism of the hammer at high frequency and with high power. When the water leaves the hammer, it has a low pressure and very low flush velocity (100-500 ft./min.) (30-150 m/min.) which is still adequate to bring the cuttings to the surface and to clean the borehole. Further, the hydrostatic column created above the hammer helps to keep the hole stable and prevents collapse, while in strata with high water tables it prevents ground water being sucked into the hole: this would have detrimental hole stability and potentially environmental implications.

### WDTH EQUIPMENT DETAILS

Table 1 shows the range of hammer and bit sizes, while the overall system organization is shown in Figure 4. With respect to the individual components, the following points are especially relevant.

Table 1. Range of hammers, bits and operating parameters (courtesy of LKAB Wassara).

| Hammer        | Ø Drill bit                       | Water consumption             | Max operating pressure |
|---------------|-----------------------------------|-------------------------------|------------------------|
| W50 (1 1/2")  | 60mm, 64mm (Ø 1 1/4", Ø 1 1/2")   | 80-130 l/min (20-30 USgpm)    | 170 bar (2480 psi)     |
| W70 (1 3/4")  | 82mm, 89mm (Ø 1 1/2", Ø 1 3/4")   | 130-260 l/min (30-70 USgpm)   | 180 bar (2610 psi)     |
| W80 (3 1/8")  | 95mm (Ø 1 1/4")                   | 130-260 l/min (30-70 USgpm)   | 180 bar (2610 psi)     |
| W100 (1 1/2") | 115mm, 120mm (Ø 1 1/2", Ø 1 1/4") | 225-350 l/min (60-90 USgpm)   | 180 bar (2610 psi)     |
| W120 (1 1/2") | 130mm, 140mm (Ø 1 1/2", Ø 1 1/2") | 300-450 l/min (80-120 USgpm)  | 180 bar (2610 psi)     |
| W150 (1 1/2") | 165mm (Ø 1 1/2")                  | 350-500 l/min (90-130 USgpm)  | 150 bar (2180 psi)     |
| W200 (1 1/2") | 216, 254mm (Ø 1 1/2", Ø 1 1/2")   | 470-670 l/min (125-180 USgpm) | 150 bar (2180 psi)     |

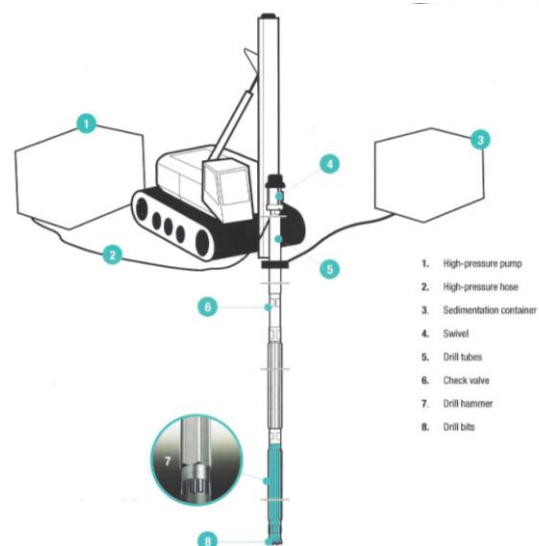

Figure 4. WDTH system components (courtesy of LKAB Wassara).

**Drill Bits:** These are of high quality, incorporating an impact surface and flushing channels, specifically designed to enhance productivity and improve wear resistance.

**Check Valve:** This is used to ensure that the hammer function is not disturbed by particles entering the hammer from the drill bit side when the hammer is shut off when, for example, changing drill rods. This feature is particularly useful when drilling deep holes or when drilling through fine grained sediments. The check valve has also a fully closed / fully open function which can be activated.

**Drill Rods:** These are thick-walled, friction welded tubes with O-ring sealed tube threads, to minimize water loss at these locations. If leakage should occur, the pump delivery rate is increased slightly to maintain the target hammer operating pressure. It may be noted that the use of water, and sealed-connection rods greatly reduces the safety risk arising from spraying of debris, which often occurs when drilling with air, and standard rods. The typical combinations for hard rock drilling are as follows:

| HAMMER | ROD DIAMETER (MM) | ROD THREAD |
|--------|-------------------|------------|
| W50    | 48                | API NC13   |
| W80    | 76                | API 2 5/8  |
| W100   | 89                | API 2 5/8  |
| W120   | 102               | API 3 1/2  |
| W150   | 114               | API 3 1/2  |

These rods are manufactured in standard lengths of 1,000, 1,500, 2,000 and 3,000 mm (approximately 3.3, 5.0, 6.6 and 10.0 feet, respectively). Casing diameters of 4½ to 8½ inches (101-216 mm) can be accommodated.

Swivels. Two different designs are available to permit drilling rigs to operate WDTH, and are built to be maintenance free. They have a roller bearing-free design, with water lubricated sliding bearings and seals. Swivels can be mounted either on top of the rotary head, or under the head (and so above the uppermost rod).

Water Pump Units: Dedicated units are used for each of the different hammer sizes. The pump features include a water inlet buffer if drilling with an irregular water supply, a dampening system for the pressure return pulses generated by the hammer, and a control system that optimizes the drilling operation as well as the fuel consumption. The operation of the pump is highly automated, so reducing labor requirements and maintenance. It is standard to have diesel power, but electric drive pumps are often used in urban environments, and soundproofing is also a common option.

Water Supply and Consumption. Water should be fresh, and contain particles of no more than 50 µm maximum size. The WDTH pumps contain an inlet water filter to further prevent malfunctions of the hammer. Salt water can be used, but special maintenance details need to be implemented, such as flushing the system with fresh water before stand-down periods. Recirculation of the flushing water is not recommended as this can cause accelerated wear of the internal components of the hammers. Water consumption is modest: for example, when drilling a 4½ -inch (114 mm) hole with the W100 at full power, the requirement is 55 to 90 gpm (208-340 l/min.) (at service limit). This is equivalent to an hourly consumption in the range of 7.1 to 12.5 m<sup>3</sup> at 60% drilling activity.

Flushing Water Treatment: The activating water is not contaminated since no lubricants are used in the hammer. Thus, if the ground is not contaminated, the flush return is not contaminated and requires no special measures during the collection and disposal processes.

## SUMMARY OF ADVANTAGES OF WDTH

Cost Effectiveness: The hammer is always in contact with the bit, and so impact energy does not diminish with depth, when increasing water heads are encountered. Drilling depths of around 1,500 feet (450 m) can be readily achieved. For WDTH drilling, the hammer, and the high pressure pump, are much more energy efficient than an equivalent air-powered DTH system, resulting in significantly lower fuel consumption. For illustration, a typical air compressor has an efficiency of 7-10%, compared to a plunger water pump's efficiency of about 90%. Typical values for average fuel consumption when drilling with the W120 hammer and a 130 mm bit are:

- Idling, 1.1 to 1.3 gallons/hour (gph) (4-5 l/hr.)
- Medium power (including when casing), 4 to 5.3 gph (15-20 l/hr.)
- Maximum power, 6.6 to 7.9 gph (25-30 l/hr.)

These are measured values, based on 60% drilling time.

Clean Water for Powering the Hammer is Environmentally Harmless. The use of clean, oil-free water for powering and lubricating the hammer means that neither the borehole nor the flushing water carrying the cuttings is contaminated by oil. Likewise, there is no dust or oil mist which can cause air pollution, or which needs to be captured.

### Drilling System Advantages.

- There is reduced component wear since the velocity of the flushing water is relatively low, resulting in low rates of wear on the surface of the hammer and drill rods. It is not unusual for the service life of the W100 hammer body to be up to 30,000 lft (10,000 lm) even in very abrasive conditions, while the limitation on rod usage is typically thread wear. Hammers are serviced every 5,000-10,000 lft (1,500-3,000 lm) of drilling, depending on water quality.
- Less harm is caused to the ground since the flushing water exits the hammer under low pressure and, given the fact that the rate of flow is moderate, the uphole velocity is correspondingly low. Further, the hydrostatic pressure created by the flushing water helps stabilize the hole wall and therefore promotes straightness in

soft formations or overburden by reducing “overbreak.” Likewise, such low uphole velocities permit the use of tight tolerance hammer and rod stabilizing devices further enhancing straightness, and deviations in the range of up to 1 degree can be anticipated, and values less than 0.2 degree can be achieved. This “gentle” drilling mechanism supply reflects the fact that water is an incompressible medium, unlike compressed air – the volume of which expands as pressure reduces (such as occurs when air flush passes out of the hammer and begins to move up the drill hole annulus).

## **SUMMARY OF DISADVANTAGES OF WDTH**

Water consumptions are not insubstantial and so WDTH may not be a potential tool in very arid areas, especially since recirculation of flush water is not advisable. Also, it is fair to say that the components (however, rods and pumps especially) are higher priced than conventional air-powered DTH. However, in this regard, WDTH will still prove attractive when its advantages, in terms of productivity, depth, environmental impact and so on, are weighed.

## **WDTH APPLICATIONS**

Routine Construction Drilling in Rock or Concrete. WDTH is routinely used for drilling production holes for grout curtains throughout the world. The fast, straight, environmental nature of the drilling is particularly appreciated in this application where water flush is essential for the high efficiency of the subsequent grouting operations. Significant examples in the U.S. from 2002 onwards include McCook Reservoir and Thornton Reservoir, Chicago, IL; Wolf Creek Dam, KY (where both 4-inch and 8-inch holes were drilled for grout holes, and for guided pilot holes, respectively); Clearwater Dam, MO; and Center Hill Dam, TN (Bruce, 2012). Other applications include drilling for anchors and micropiles, typically in the range of 3- 6½ inches (76-165 mm) in diameter.

As noted in Section 1 (above), the first U.S. application was at the McCook Reservoir, where a test program was conducted partly to determine the optimal drilling method. Two parallel rows of inclined grout holes were drilled, each row containing 128 holes to depths over 400 feet (135 m). One row was drilled with conventional rotary methods, the other with a Wassara W80 hammer, 3.75-inch

(95 mm) diameter bit, and 3-inch (76 mm) diameter drill rods. In the Silurian Dolomites and limestones of the site, the test results showed the WDTH to be over 100% more productive than the rotary system, while the average deviation at maximum depth was restricted to just over 1%. As a result, the WDTH was specified by the U.S. Army Corps of Engineers for the following 874,000 lft (266,000 m) of production drilling for the grout curtain.

Drilling in Sensitive Areas. Urban areas are usually “sensitive” in the sense that they have limited capacity to absorb movements and/or changes in groundwater level due to drilling operations. Furthermore, the injection of air or oil into the ground is typically prohibited. Due to the incompressible nature of the water flush, and its low uphole velocity, over-pressurization risks are minimized unlike the case with compressed air. WDTH’s are also very quiet, do not create dust, and do not use lubricants.

Overburden Drilling. WDTH’s can be used with a variety of overburden drilling systems, most notable and recently the Rotolock system of Center Rock Inc. (Bruce, 2012a). The water helps to lubricate the system, promoting a smoother drilling operation even through complex and variable conditions, from soft clays and sands to boulders and old timber piles. WDTH’s are particularly efficient for deeper holes in areas of high water tables and, as noted above, cannot cause over-pressurization of the formation, as compressed air can do. The environmental advantages (e.g., no oil, dust, reduced noise) are as described for the previous applications. Casing systems of diameter 4½ to 8½ inches (114-216 mm) are standard. When drilling with overburden systems or in soft rocks, the hammer pressure is reduced to about 50% of that for harder rock drilling.

Geothermal Drilling. This typically involves the drilling of deep holes which have to be very straight to avoid intersection. This plays to the WDTH’s strengths, especially in urban areas where space for installing replacement holes may be at a premium. The environmental and operational advantages listed for previous applications remain in play. On a recent project in Malmö, Sweden, 75 holes each 900 feet (270 m) long were drilled through saturated soil and rock formations. The maximum allowance for return water to the sedimentation system was 190 m<sup>3</sup> per day, which was satisfied by WDTH drilling. A previous test with air DTH drilling had

produced 100 m<sup>3</sup> per hour which had to be contained.

Jet Grouting. When jet grouting in difficult bouldery conditions, it is a common requirement to have to predrill the hole to permit the jet grouting rods and monitor to be subsequently placed. A new development in WDT technology permits single pass jet grouting whereby the jetting can be conducted through the specially adapted hammer, and the sealed-connection drill rods. Precutting of the formation during drilling with water or air can still be accomplished, leading to enhanced column diameter with this otherwise conventional, one-fluid jet grouting system. The standard hammer is the W100 JG, equipped with a 6-inch (152 mm) diameter bit. This requires 52-93 gpm (197-352 l/m) of water at 170 bars. A maximum grout delivery pressure of 500 bars can be accommodated. The hammer activation, and the jet grouting operation, are each controlled independently by different pumps.

Marine Drilling Operations. The main advantages of WDT's in this applications are:

- Penetration rate does not decrease with depth as is the case with air-powered hammers.
- No oil is introduced into the water.
- There is minimal risk of over-pressurizing the formation.

Exploratory Drilling. WDT is being increasingly used to lower mineral exploration costs by providing relatively fast methods to penetrate to the "pay zone" to be cored. Such non-cored horizons will typically comprise overburden, fills, moraine/till, and rock above the ore body. WDT drilling can be conducted for both surface and underground excavation, in conjunction with standard core rigs (which also use water flush). Experience shows that the average WDT penetration rate is up to 5 times that of core drilling. The extreme straightness of the WDT holes is also a considerable advantage of this application. Figure 5 shows the details of the exploratory drill system setup, designed to accommodate N-size (3-inch) coring afterwards.

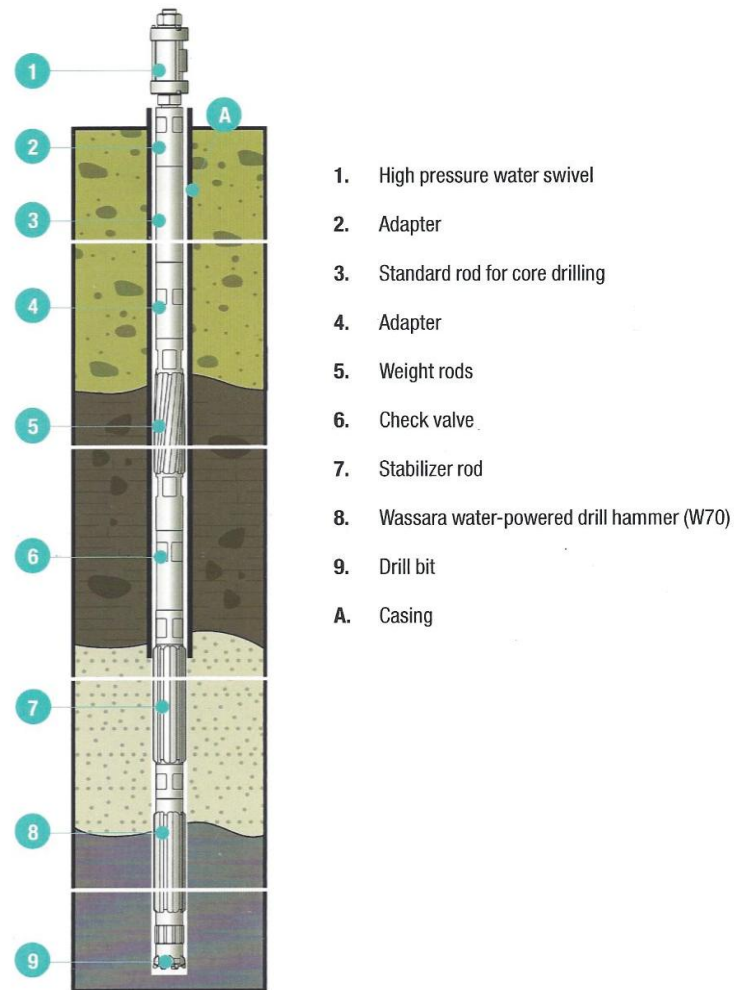

Figure 5. WDT system for Exploration (courtesy LKAB Wassara).

It is specifically recommended that:

- To avoid the risk of wear being caused by the vibrations from the hammer, "weight rods" be incorporated in the standard drill string.
- The WDT should operate at around 70 bars water pressure during casing installation, and up to 180 bars during rock drilling.
- PCD (Poly-Crystalline Diamond Composite) bits limit wear on the bit perimeter promoting hole verticality and optimizing bit life. However, classic TC (tungsten carbide) bits can be used if the formation is favorable (i.e., non-abrasive).

Mining. The particular demands of the deep mining industry (especially fast penetration, hole straightness, reduced rate of bit wear, and enhanced safety and environmental



considerations) initially drove the development in Sweden of WDTH's. In the words of the Wassara promotional brochure, "In short, it (i.e., WDTH) enables mining companies to scale up, improve safety, lower their energy consumption and minimize the impact on the environment." The fundamental driving principle was that pressurized water can provide a high frequency and high energy per blow and, when exhausted through the hammer, still had sufficient uphole velocity to flush and clean the hole. In support of these claims, Wassara claims:

- Deviations < 1% as opposed to 10-20% with top hammers.
- Energy consumptions are about 20% that of an air compressor and 33% that of a top hammer.
- Uphole velocity of 100-200 ft./min. (30-60 m/min.) as opposed to air at over 7,000 ft./min. (2,130 m/min.).
- Frequency of blows (3,600 bpm) higher than air-powered DTH (2,000-2,700 bpm).

#### **FINAL REMARKS**

WDTH's are a proven method for safe and efficient drilling in all — and especially sensitive — formations. The use of water as a power transmitter to the hammer has fundamentally changed DTH drilling principles and, water being incompressible, ensures minimal power loss to great depths under the ambient water table. WDTH drilling is applied from both surface and underground locations and already has a rich history of usage in the U.S. Its other main advantages over conventional air-powered DTH's include superior productivity, straighter holes, protection of the environment (subsurface and atmosphere), and much reduced energy requirements.

#### **REFERENCES**

Bruce, D.A., 2012. "Specialty Construction Techniques for Dam and Levee Remediation," Spon Press, an imprint of Taylor and Francis, 304 pp.

Bruce, D.A., 2012a. "The Evolution of Small Hole Drilling Methods for Geotechnical Construction Techniques," ADSC EXPO, ADSC: The International Association of Foundation Drilling, March 14-17, San Antonio, TX, 18 pp.

Littlejohn, G.S. and D.A. Bruce, 1977. "Rock Anchors - State of the Art." Foundation

Publications, Essex, England, 50 p. (Previously published in Ground Engineering in 5 parts, 1975-1976.)

Lyon R. and R. Soppe, 2012. "Drill Tooling: Down Hole Hammers," Presentation at the ADSC Drill Operator School, September 11, Greensboro, NC.

McGregor, K., 1967. "The Drilling of Rock," C.R. Books Ltd., London.

Weaver, K.D. and D.A. Bruce, 2007. "Dam Foundation Grouting, Revised and Expanded Edition," American Society of Civil Engineers, ASCE Press, New York, 504 p.